

MODEL 250 TRANSDUCER INSTALLATION

The Model 250 Pressure Transducer is a low cost wet or dry media application gage unit. This transducer is available in ranges from 100 to 10,000 PSI and features all stainless steel wetted parts. The unit produces a 2 wire 4-20mA output with 1% F.S.O. accuracy. A 3 wire 1-5 VDC output is also available.

INSTALLATION

1. Location- The model 250 pressure transducer can be placed in a NEMA 4 rated location, as vibration free as possible.

2. Attachment- The series 250 Pressure Transducer has a 1/4" NPT threaded pressure port that attaches directly to the pipe in which the media is delivered. Coat the sensor threads with an antisieze compound or Teflon tape. Attach it to the pipe using a 7/8" wrench.

ELECTRICAL CONNECTIONS

The Series 250 Pressure Transducer produces a 4-20mA or 1-5VDC signal. Power requirements are a minimum of 10 to 30 VDC with a current requirement of 30mA for the current output unit and 10mA for the 1-5 VDC output unit.

The sensor is connected via a two or three wire supply cable.

2 wire device (4-20mA output)

+ = Red
- = Black

3 wire device (1-5 Volt output)

+ = Red
- = Black
Signal = White

CAUTION: Do not exceed specified supply voltage.

2 WIRE CONNECTION

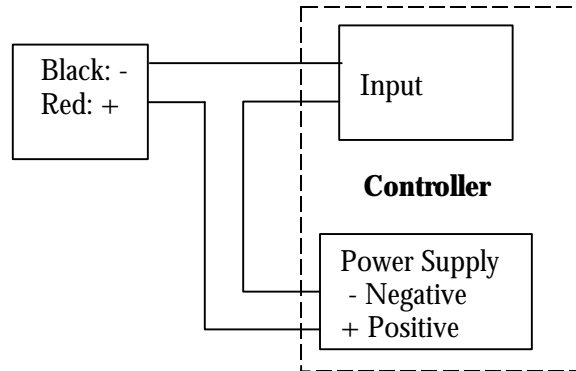

3 WIRE CONNECTION

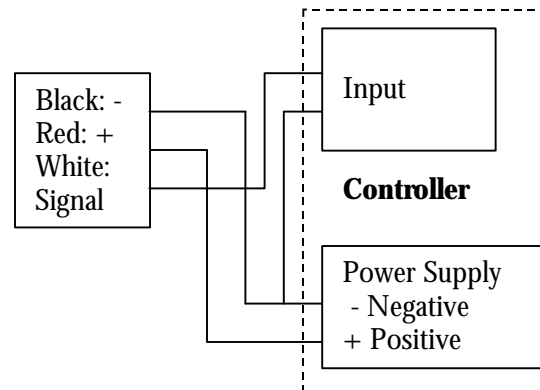

CONVERTING 4-20mA TO 1-5 VDC

250 Series Pressure transducers can be easily adapted to controllers requiring 1-5 VDC input. Insert a 250 ohm resistor between the "+" and "-" controller input terminals. This will safely convert the 4-20mA signal to the desired voltage. The sensor "+" (red) is connected to the power supply Positive. The sensor "-" (Black) is connected to the controller input "+". The Power Supply "-" is connected to the "-" controller input.

OFFSET AND SPAN

The model 250 Pressure Transducer is a self contained sealed unit that is factory calibrated. As a result the sensor has no user adjustments.

CUSTOMER SERVICE

If any problems are encountered during installation please call the number below for assistance.

Call 1-800-735-8998

For the most up to date information on all of our products visit our website at:

www.autotraninc.com

AutoTran Incorporated

7638 Washington Ave. S
Eden Prairie, MN 55344
Phone: 1-800-735-8998
1-(952) 942-8743
Fax: (952) 942-8753